

产品规格/承认书

PRODUCT SPECIFICATION / APPROVAL SHEET

客户 CUSTOMER:

杰晟型号 JASONFAN MODEL No: FE22080PABD

马达规格 MOTOR SPECIFICATION : M3G05513-EA

客户型号 CUSTOMER MODEL NO:



本承认书内容若贵公司确认无误，
恳请于下方承认栏内签章寄回。
Please confirm your acceptance of this
approval sheet by return fax.

承认栏
CONFIRMATION SIGNATURE

温州杰晟风扇制造有限公司
WENZHOU JASON FAN
MANUFACTURER CO.LTD

浙江省乐清市兴湖路 98 号
NO.98 Xinghu Road Yueqing,Zhejiang,China
Tel:+86-577-55775657
Fax:+86-577-61521177
E-mail:jasonfan@jasonfan.cn

SPEC NO.编号	JSEC220M2-001
Issue Date 初审日期	05/12/2024
Edition 编辑人员	4
Revised Date 复审日期	06/12/2024

MAKE	CHECKED	REVIEW	APPROVED
王相仕	林令丰	赵佰可	郑林森

A. 一般规格 (General Specification)

项 目(Item)		规格 / 条件(Specification / Condition)	
01	型号(Part No.)	FE22080PABD	
02	电机结构 (Motor Structure)	永磁直流电机 (Permanent magnet DC Motor)	
03	外型尺寸(Outline Dimension)	220*220*80 mm	
04	额定电压(Rated Voltage)	AC 220V	
05	额定电流(Rated Current)	0.30A±0.02A	
06	额定频率(Rated Frequency)	50/60HZ	
07	使用电压范围(Voltage Range)	AC 200V ~ AC 240 V	
08	额定输入功率 (Rated Input Power)	43W	±5%
09	转速(Rated Speed)	2800 RPM	±5%
10	最大风量(Max. Airflow)	602CFM 1020m3/h	a. 额定电压(Rated Voltage) d. 25 °C
11	最大静压(Max. Static Pressure)	0.75in-H ₂ O 187Pa	b. 标准(Standard):AMCA c. 额定电流(Rated Current)
12	最大噪音(Max.Noise)	61 dB(A)	d. 自由出风(Free outlet of air) e. Measured after 5 min.
13	电机使用寿命(Motor Life)	平均 50000/h hrs at 40°C	a. 额定电压(Rated Voltage) b. 65 % RH
14	旋转方向(Rotation Direction)	逆时针(Counter-Clockwise)	
15	转速控制(Speed Control)	电位器或电压控制 (Potentiometer or Voltage Control)	
16	信号输出(Signal Output)	转速信号输出(示波器) RPM Signal Output (Oscilloscope)	

B. 电器规格 (Electrical Specification)

项 目(Item)		规格 / 条件(Specification / Condition)	
01	制造标准 (Manufacture Standard)	GB12350、GB/T 5171、GB/T 14711、EN 60335-1、EN 61000-6-2、 EN 61000-3-2/3、EN 55022、CE	
02	电机保护形式 (Type of protection for motor)	极性保护(Polarity protection) 堵转保护(Locked rotor protection) 自动重启(Automatic restart capability) 软启动(Soft Starting)	
03	绝缘等级 (insulation Grade)	Class B	
04	防护等级 (Protection Grade)	IP 55	

C. 安全规格 (Safety Approvals)

安规(Safety)	CCC	CE	RoHS
安规编号(File No.)	√	√	√

D. 主要材料/零件规格 (Main Materials / Parts Specification)

项 目 (Item)	规格 / 条件 (Specification / Condition)
01 外壳 (Frame)	铸造铝合金 ADC12 压铸成型, 表面银灰色烤漆抗腐蚀处理。 (ADC 12 Aluminium alloy die-casting, surface is finished by gray paint anti anti-corrosion treatment)
02 风叶 (Impeller)	PPE+V0 级阻燃剂, 黑色塑料注塑一次性成型 (black plastic injection disposable moulding made of PBT+30% glass fiber+V0 class of anti-burning liquid)
03 轴承 (Bearing)	免更换滚珠轴承。 (maintain-free NMB ball bearing.)
04 漆包线 (Enamelled copper wires)	耐温 180°C (heat resisting 180°C)
05 线圈骨架 (Coil frame)	厚度为 h 的燃烧性 V-0 (Thickness H Flame-retardant V-0)
06 电路板 (PCB)	双层线路板 94V-0 (Wiring printed double layer board 94V-0)
07 引线 (Lead wire)	UL 3266 - 18#、UL 3385 - 22#
08 端子 (Terminal)	500DS
09 重量 (Weight)	1.66kg

E. 适用条件与范围 (Application Conditions And Range)

项 目 (Item)	规格 / 条件 (Specification / Condition)
01 运行温 / 湿度范围 (Operation Temperature/Humidity)	温度 (Temperature) -10 °C—70 °C
	湿度 (Humidity) 66% (RH)
02 贮藏温 / 湿度范围 (Storing Temperature/Humidity)	温度 (Temperature) -30 °C—70 °C
	湿度 (Humidity) 66% (RH)

a. 非凝结状态 (Non-condensing condition)
d. 25 °C

F. 电机引线定义 (Motor lead definition)

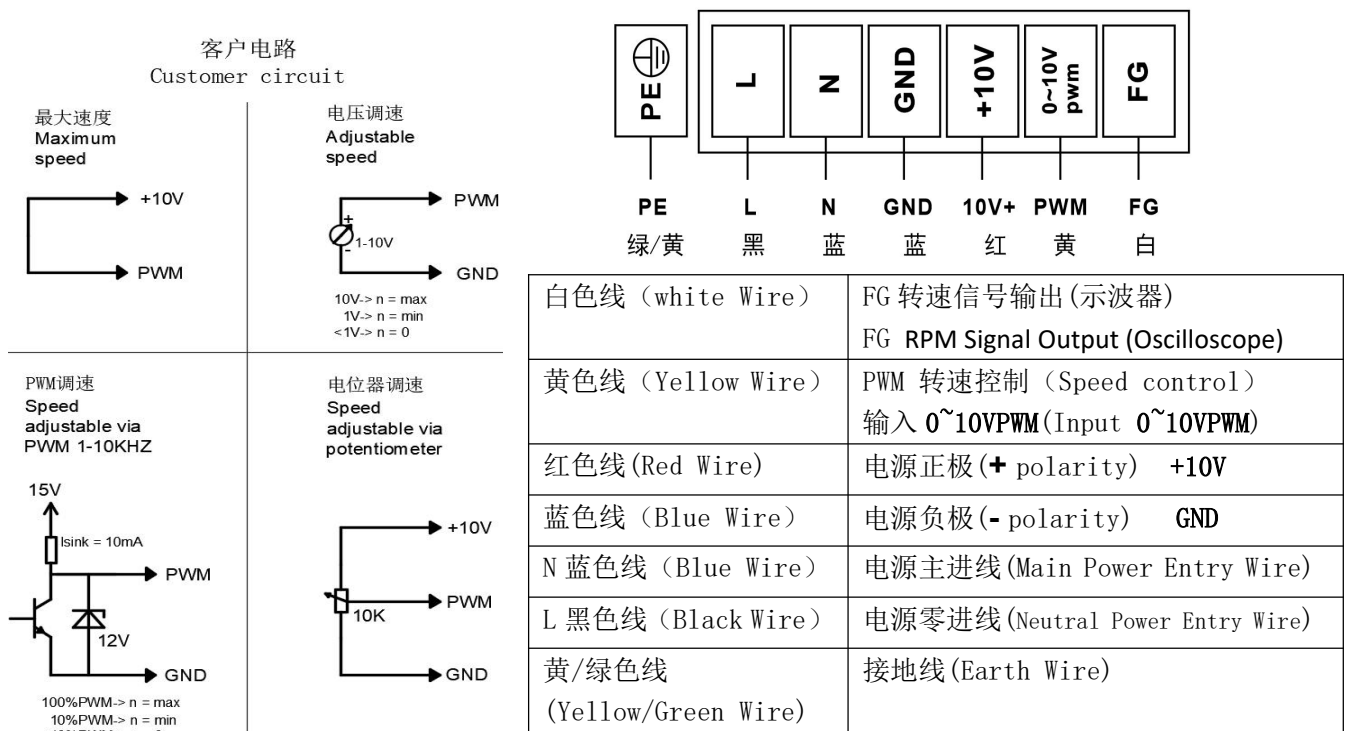

G. 风量特性图 (Airflow curve chart)

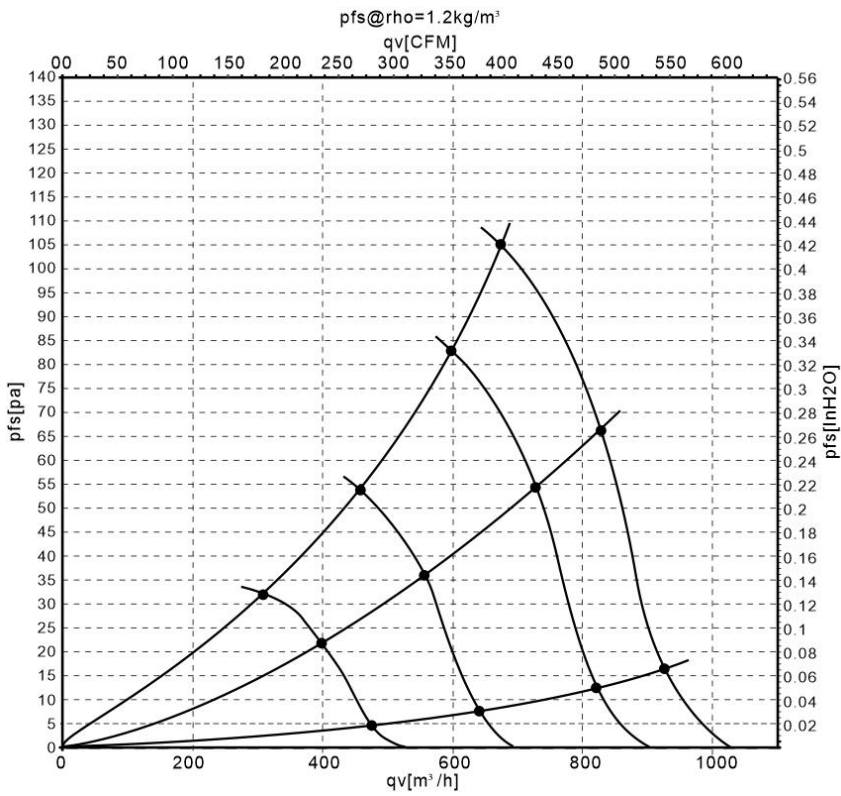

风量性能按照 ISO5801 安装类别进行测量。吸入侧噪声水平：按照 ISO13347, 在距离风扇轴 1 米处测量 LpAin 值。给出的值在上述条件下测量有效，会根据实际安装情况有所不同。在完全密封时，最大静压为 187Pa。

Air performance measured as per ISO 5801 Installation category. Suction-side noise levels: measured as per ISO 13347, LpAin measured with 1m distance to fan axis. The values given are valid under the measuring conditions mentioned above and may vary according to the actual installation situation.

When fully sealed, the maximum static pressure is 187Pa.

	U	f	n	I	LpAin	qv	Pfs
	V	Hz	min ⁻¹	A	dB	m ³ /h	Pa
1	230	50	2815	0.34	60	1020	0
2	230	50	2770	0.40	61	925	17
3	230	50	2730	0.43	61	819	66
4	230	50	2730	0.46	62	670	105
5	230	50	2500	0.25	57	901	0
6	230	50	2500	0.32	58	820	12
7	230	50	2500	0.35	59	701	55
8	230	50	2500	0.41	61	541	82
9	230	50	2000	0.15	38	706	0
10	230	50	2000	0.17	46	643	8
11	230	50	2000	0.19	50	541	37
12	230	50	2000	0.22	55	419	54
13	230	50	1500	0.08	36	522	0
14	230	50	1500	0.09	37	476	4
15	230	50	1500	0.10	40	393	22
16	230	50	1500	0.11	45	311	32

U= 电压 (Supply voltage)、 f = 频率 (Frequency)、 n = 转速 (Speed)、 I = 电流 (Current draw)、

LpAin = 进口侧声压等级 (Sound pressure level inlet side)、 qv = 空气流量 (Air flow)、 Pfs = 压强 (Pressure increase)

H. 噪音测量条件 (Noise Measure Condition)

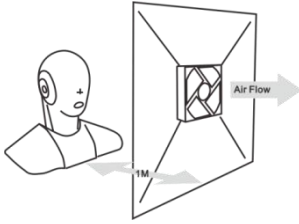

- | |
|--|
| 1. 24dB (A) 静音室 (24dB (A) Sound off room) |
| 2. 数字分贝测量系统 (Digital Decibel Measuring System) |
| 3. 移动分析系统 (Mobile Analyze System) |
| 4. 标准: (Standard) ISO 13347, ISO 3744, CNS 8753, |

I. 商标 (Label Marking)

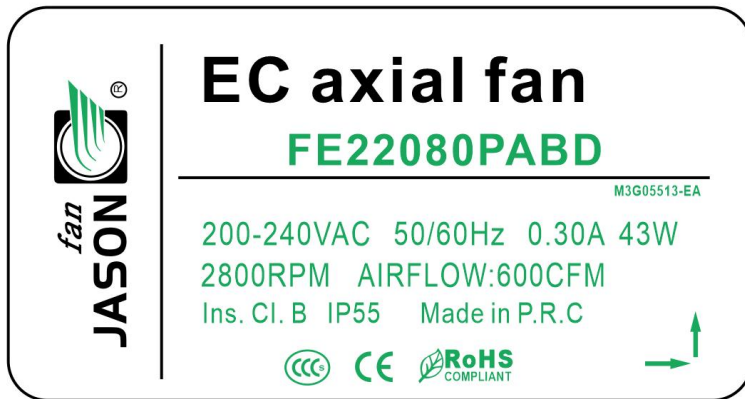

J. 外观尺寸图 (Outline Dimension)

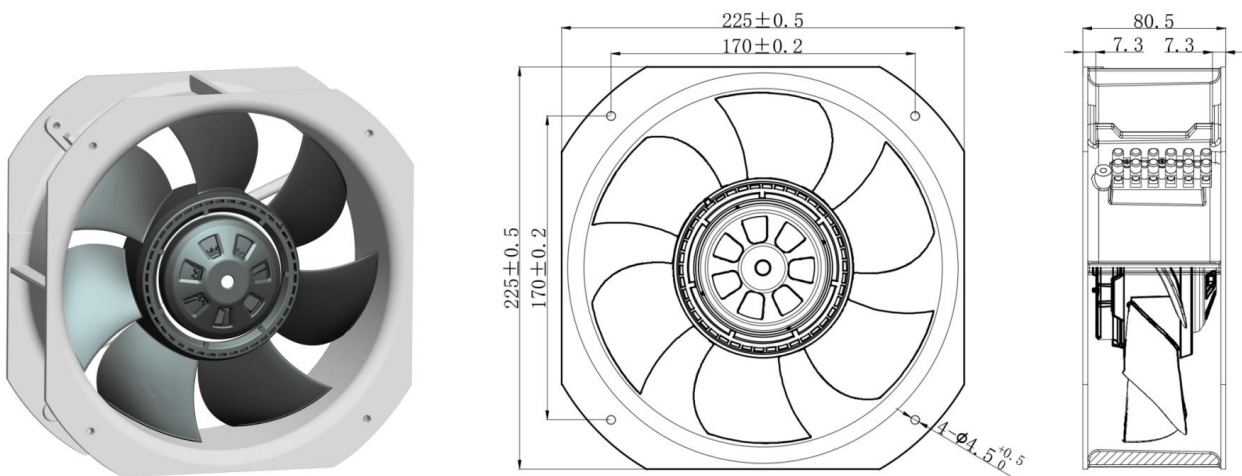

K. 产品代号说明 (General Model Note)

FE	220	80	P	A	B	D
风扇类型 Fan Type	外形尺寸 Size of Frame	外框厚度 Thickness of Frame	塑料扇叶 Plastic Fan	铝合金外壳 Aluminium Frame	滚珠轴承 Ball Bearing	端子 Terminal

备注 (REMARKS)

1. 电气参数和运行时的环境有关，以上数值仅为参考标准，来源于标准环境下的试验测试。
(Electrical parameters measured under standard environment are for reference only, which are related with operation environment.)
2. 假如使用时超出本产品规格所定的极限，我们将不保证此产品。
(We will not guarantee the products if the application of our products are exceeded the limitation which is specified on this specification.)
3. 如参数有异常或偏差，要提交书面请求，由杰晟 审批。
(A written report should be submitted to JASON FAN for approval if specifications are abnormal and deviation.)
4. 寿命测试是统计法下的一个推论值，不同于产品保证期。
(Life test is a deductive figure under statistical method and it is different from product warranty.)
5. 安装风扇时要采取必要的预防措施。推荐使用网罩，以避免人员受伤。
(Take necessary precaution when installing fans. Finger guards are recommended to prevent personal injury.)
6. 按照产品上标示的接线方式接入相应的电源，并正确连接接地线端，风扇运转风叶为逆时针。
(Connect the fan to power and ground according to the wiring diagram indicated in the fan. The direction of the air is counter-clockwise seeing from front impellers.)
7. 本产品不保证因粉末、水滴、小虫进入而导致的安全规范问题与不良品产生。
(No guarantee on the products against the safety problem or failure caused by powder)
8. 风扇运行后有异常噪音，请将异常样品寄给杰晟做分析。
(If abnormal sound caused after fan running, please send abnormal samples to JASON FAN for analyze.)
9. 产品在运转时不可将异物或人手伸入风叶运转范围内，安全安装后，确保风扇开始运转前风叶的转动是自由无阻的。
(Don't drop any foreign matter into the fan, or touch the impeller by hand; after safty installation, make sure that the fan rotation is unhindered and free before running.)
10. 风扇储存在干燥通风处。湿度不能过高对产品有害。
(Fans are to be stored in a dry and cool place. High levels of humidity are harmful to products.)
11. 不是很适合腐蚀环境，煤矿井下。液体，气体，煤尘等。
(Don't bring the fans to corrosive and mine environments, including liquids, gases, or coal dust.)
12. 请小心。杰晟对由于风扇安装错误而引起的过度共振，震动，造成质量问题不负责任。
(Please noted that JASON FAN is not responsible for any quality issues such as excess resonance and vibration caused by incorrect mounting of fans.)
13. 在搬运或作业过程中，如果风扇从1米的高度掉落，将会对叶片的平衡产生一定的影响。当轴承为滚珠轴承时，应避免掉落。
(It is very important to notify that avoid to drop from 1meter height when in any movement or operation, It will impact the balance of blade. Especilly ball bearing structure is avioded to drop down.)

如果型号代码或性能改变，以上文件应及时更新

The above document should be updated in time when Model code or performance changes.