

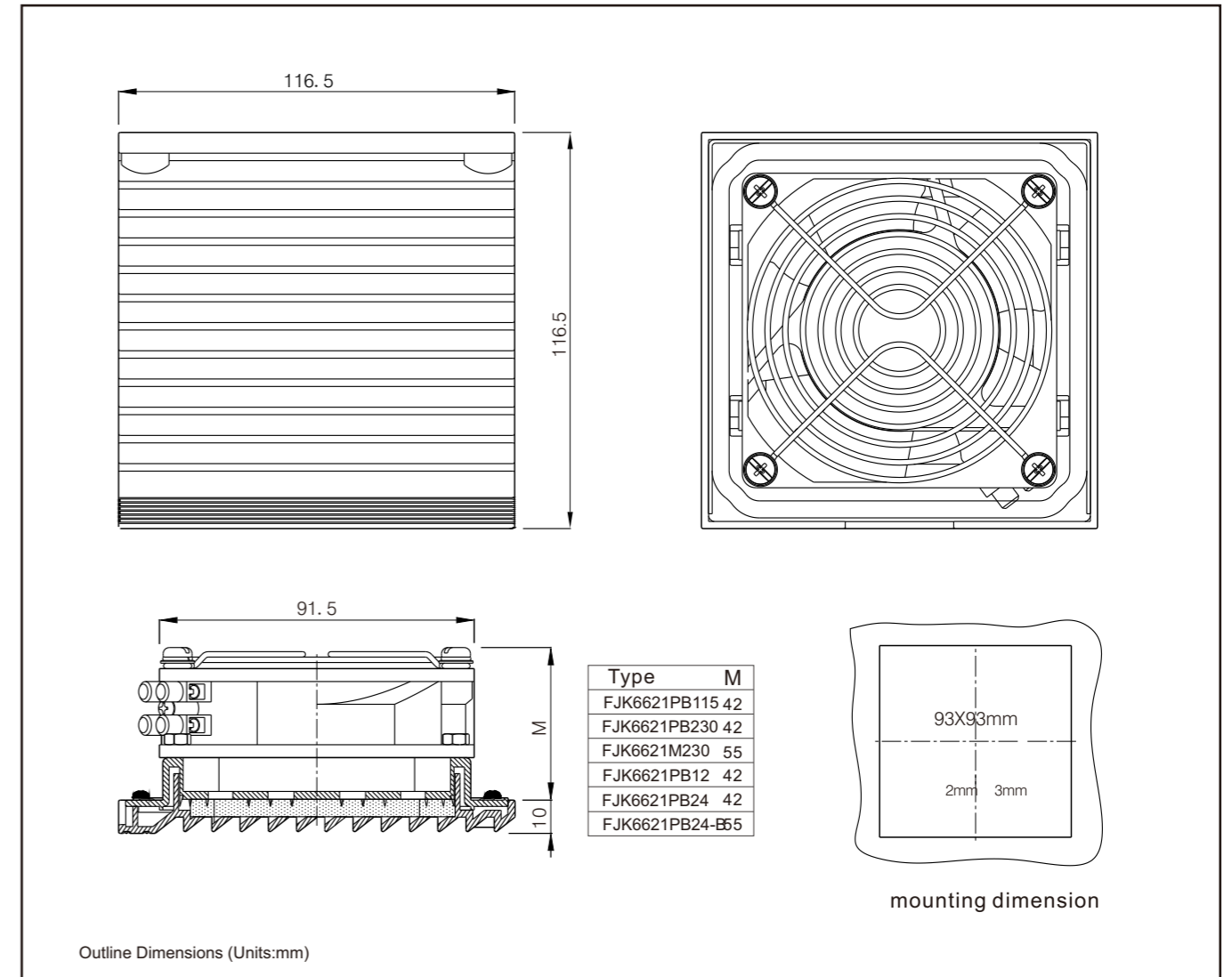

Characteristics:

- 1 It comprises of a axial fan, a protective housing on the front and rear surfaces and filter designed to retain dust particles.
- 2 The filters that equip the fans must be cleaned and replaced regularly.
- 3 It can produce all kinds of flame retardant V0 grade material and filter panel.
- 4 Material of filter pad: 100g/ M3 nylon fiber compound, Filtration efficiency up to 7 3%.
- 5 Operation Temperature/Humidity Range: (under unconcretionary state) -20°C ~ +65°C (temperature), 0% ~ 95% (himidity)
- 6 RAL 7035 grey is the standard offer with the possibility to change to RAL 7032 by means of a replacement grille.
- 7 Bear in mind the pressure losses caused by the outlet element (grille with filter, ventilation louvre or simple opening) when determining the fan flow rate.
- 8 Protection class: E N 60 5 29 IP 5 4 (not suitable for outdoor equipment).

1	V0		
2	100g/ M3		70 %
3	/		-20 ~+65
4			0%~95%
5			
6	RAL7035	RAL7032	
7			
8	EN 60 5 29 IP 5 5		



- A installation: No need of screw, snap-in installation
- B Power connection: Terminal connection (wire connection)
- C With seal ring
- D Maximum weight: 370g

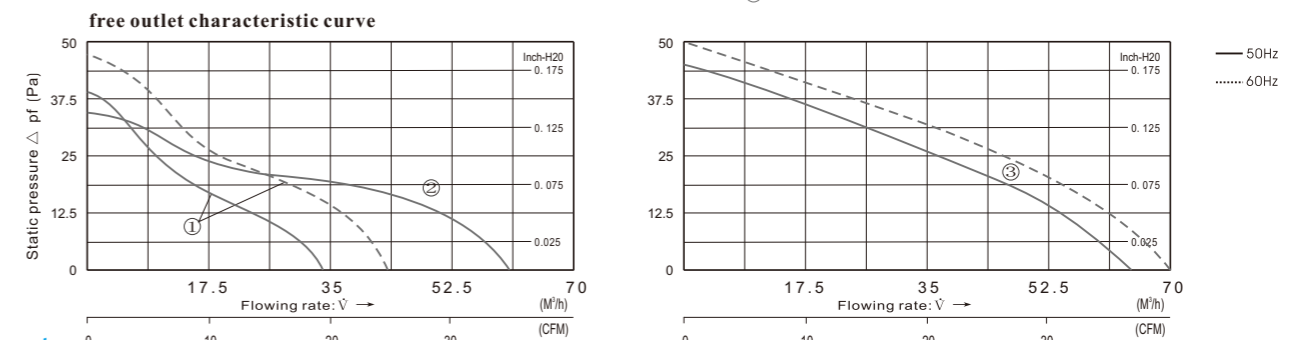

Parameters

Type	Fan Model	Rated Voltage	Speed	Frequency	current	Power	Max Air Flow	Static Pressure	Noise Curve	external dimensions
		V	V	Hz	(A)	(W) _{10% 20%}	m3/h	(Pa)	(dB)	(mm)
FJK6621PB115	FJ9021AB	115 AC	75...125	50	0.13	12	34	39	32	116.5x116.5x52
				60	0.12	11	42	45	34	
FJK6621PB230	FJ9022AB	230 AC	150...250	50	0.06	12	34	39	32	
				60	0.07	11	42	45	34	
FJK6621M230	FJ9032MAB	230AC	110...250	50	0.08	13	65	45	36	
				60	0.07	11	70	50	36	
FJK6621PB12	FJ9025PB12	12 DC	6...13.8		0.22	2.64	70	45	36	①
FJK6621PB24	FJ9025PB24	24 DC	10...27.5		0.12	2.88	70	45	36	②