

EXTERNAL ROTOR MOTOR FAN

220mm

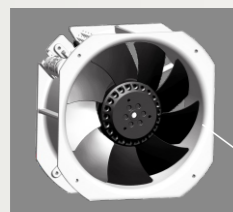

1 White Shell

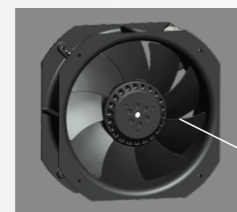

2 Black Shell

- 1 **Frame**
Aluminum die-casting, surface is finished by anti-corrosion treatment with primary color or black electrophoresis anti-corrosion treatment
- 2 **Impeller**
Metal impellers are welded to motor rotor, and surface is finished by black electrophoresis anti-corrosion treatment
- 3 **Operation Temperature/Humidity**
Temperature -40°C ~ +80°C Humidity 0% ~ 95%
- 4 **Protection**
Motor Internal with automatic recovery thermal protector
- 5 **Withstand Voltage**
AC 1,800V , 1 min at 0.5mA, 50/60 Hz
- 6 **Insulation System**
design according to IEC61858 Grade F,
- 7 **Protection Grade** IP44

- 1
- 2
- 3 / -40 ~ +80 0% ~ 95%
- 4 :
- 5 AC 1800V 0.5mA 50/60Hz 1
- 6 IEC61858 F
- 7 IP 44

FJ22082MAB

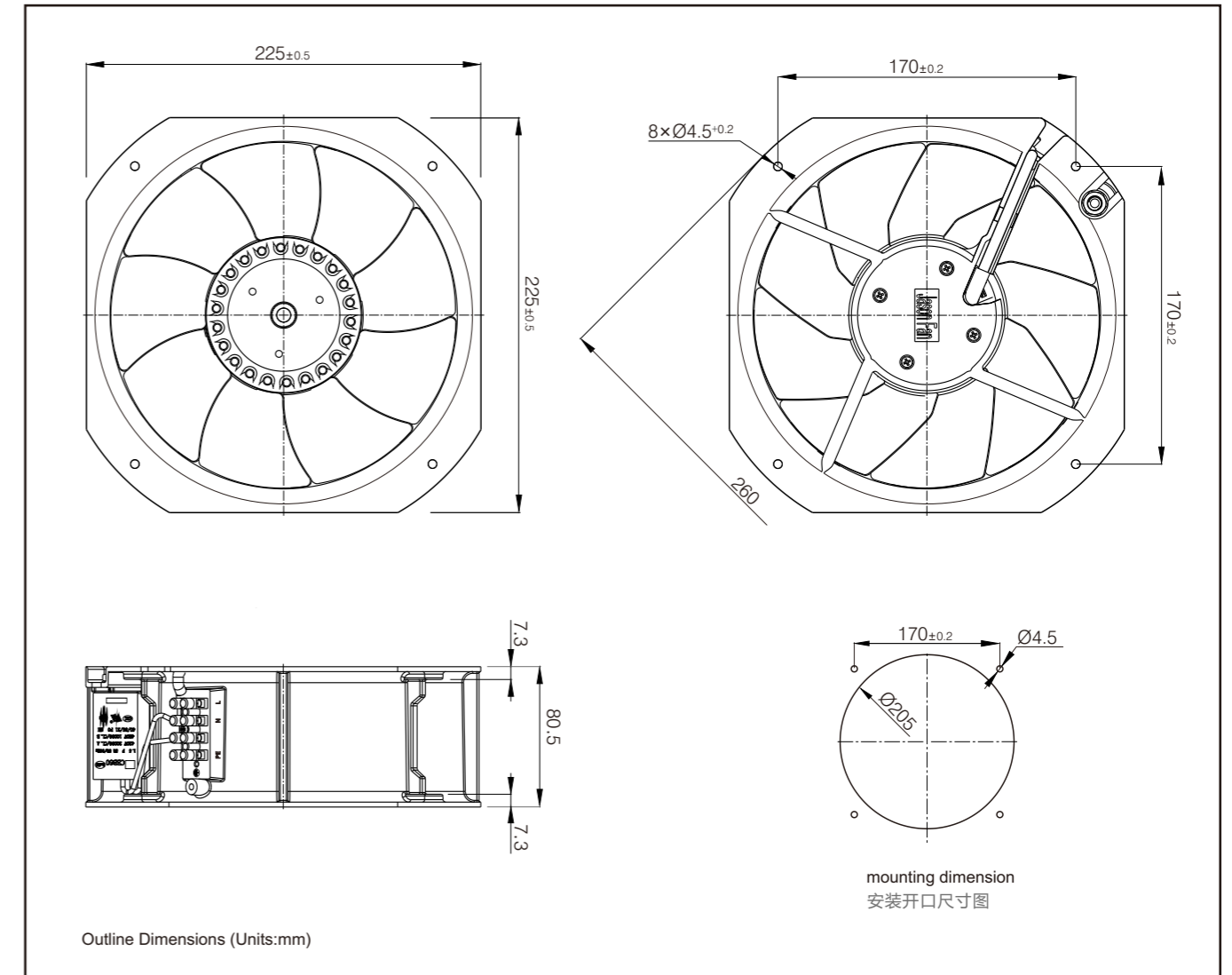

- Ⓐ Rotation direction of blades : CCW seen from the front impellers
- Ⓑ Power Connection: PA-10 terminal connection
- Ⓒ Unit weight: 2.2kg

- Ⓐ PA-10
- Ⓑ 2.2kg
- Ⓒ

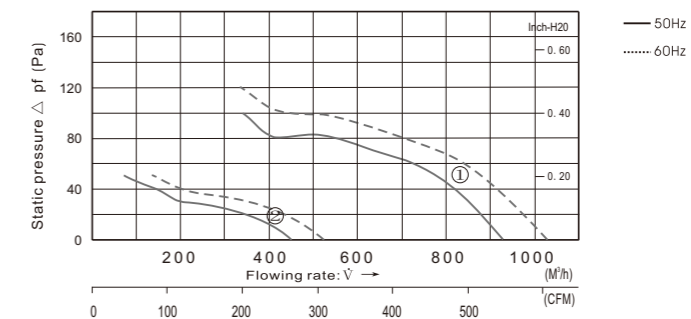

Parameters

Type	Motor	Rated Voltage	Frequency	current	Power	Speed	Max Air Flow	Static Pressure	Noise	Curve	Capacitor
		V	Hz	(A)	(W) _{10% 25%}	(min-1)	CFM m3/h	(Pa)	(dB)		(μF)
FJ22081MAB	M2S9201-AF	115	50	0.64	60	2550	546 925	100	59	①	4.0/250
FJ22082MAB	M2E9201-AF	230	50	0.30	65	2550	546 925	100	59		1.5/450
FJ22083MAB	M2D9201-AF	380	50	0.17	60	2550	546 925	100	59	②	0.5/630
FJ22082MAB-4E	M4E9201-AF	230	50	0.13	27	1350	254 430	50	40		0.68/450
			60	0.12	27	1600	313 530	50	44		